

## Instruction Manual

### Electric Pallet Truck with Scale

#### PTE15N SC

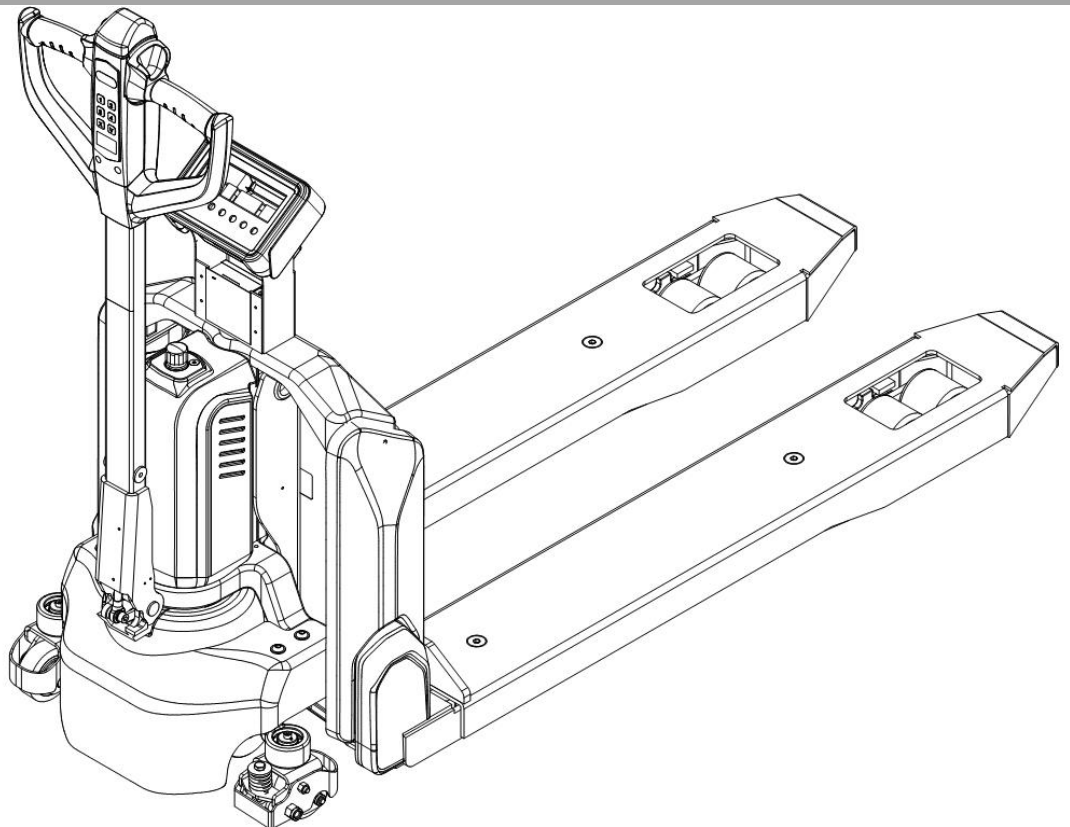

#### **WARNING**

Do not use the pallet truck before reading and understanding these instructions.

#### **NOTE:**

- Please check the designation of your truck type at the last page of this manual as well as on the ID-plate.
- Keep this manual for reference.

Version 05/2022

PTE15NSC-SMS-001-EN



## FOREWORD

Before operating the truck, read this ORIGINAL INSTRUCTION MANUAL carefully and understand the usage of the truck completely. Improper operation could create danger.

This manual describes the usage of different electric pallet trucks. When you operate or maintain the truck, make sure, that it applies to your type.

Keep this manual for reference in the future. If this manual or the warning labels are damaged or got lost, please contact your local dealer for replacement.

This truck complies with the requirements according to EN ISO 3691-1 (Industrial trucks- safety requirements and verification, part 1), EN 12895 (Industrial trucks- electromagnetic compatibility), EN 12053 (Safety of industrial trucks- test methods for measuring noise emissions), EN 1175-1 (Industrial truck safety – electrical requirements), assumed the truck is used according to the described purposes. The noise level for this equipment is 69 dB(A) according to EN 12053.

### ATTENTION:

- Environmentally hazardous waste, such as batteries, oil and electronics, will have a negative effect on the environment, or health, if handled incorrectly.
- The waste packages should be sorted and put into solid dustbins according to the materials and be collected disposal by local special environment protection bureau. To avoid pollution, it's forbidden to throw away the wastes randomly.
- To avoid leaking during the use of the products, the user should prepare some absorbable materials (scraps of wooden or dry duster cloth) to absorb the leaking oil in time. To avoid second pollution to the environment, the used absorbable materials should be handed in to special departments in terms of local authorities.
- Our products are subject to ongoing developments. Because this handbook is only for the purpose of operating /servicing the pallet truck, therefore please have understanding, that there is no guarantee out of particular features out of this handbook.



NOTE: In this manual, the left sign means warning and danger, which can lead to death or serious injury if you do not follow the instructions.

### Copyright

The copyright remains with the company, mentioned on the CE- certificate at the end of this document or, if sold within the USA, with the company, mentioned on the company sticker.

# TABLE OF CONTENTS

1. CORRECT APPLICATION .....	4
2. DESCRIPTION OF THE PALLET TRUCK .....	5
a. Overview of the main parts .....	5
b. Main technical data .....	6
c. Description of the safety devices and warning labels (Europe and other, excepting USA) .....	8
d. Identification plate .....	8
3. WARNINGS, RESIDUAL RISK AND SAFETY INSTRUCTIONS .....	9
4. COMMISSIONING, TRANSPORTING, DECOMMISSIONING .....	9
a. Commissioning .....	9
b. Hoisting/ transportation .....	10
c. Decommissioning .....	11
5. DAILY INSPECTION .....	11
6. OPERATING INSTRUCTIONS .....	11
a. Parking .....	12
b. Lifting .....	12
c. Lowering .....	12
d. Travelling .....	12
e. Steering .....	13
f. Braking .....	13
g. Malfunctions .....	13
h. Emergency .....	13
7. WEIGHING TERMINAL .....	14
a. Accurate weighing .....	14
b. 1 (Net) + 2 (Tare) = 3 (Gross) .....	14
c. Errors .....	14
d. Zero and tare functions .....	15
e. Summation (total) function .....	16
f. Printer (Optional) .....	16
g. Printout (Optional) .....	17
h. Paper replacement .....	17
8. Indicator display .....	17
a. Button and Display Check .....	17
b. Default Unit Settings .....	18
c. Backlight Mode Settings .....	18
d. Calibration .....	18
e. Battery Replacement .....	19
f. Indicator operation panel .....	20
g. Sensors Installation .....	20
h. Button Functions .....	21

9. Pin-code panel.....	22
a. Introduction .....	22
b. Main parameters .....	22
c. Main functions.....	23
10. BATTERY CHARGING AND REPLACEMENT .....	23
a. Replacement.....	23
b. Battery indicator .....	24
c. Charging.....	25
11. REGULAR MAINTENANCE .....	26
a. Maintenance checklist.....	26
b. Lubricating points.....	27
c. Check and refill hydraulic oil .....	28
d. Check electrical fuses .....	28
12. TROUBLE SHOOTING .....	28
13. WIRING/ CIRCUIT DIAGRAM.....	30
a. Electrical circuit diagram .....	30
b. Hydraulic circuit diagram .....	34

# 1. CORRECT APPLICATION

It is only allowed to use this electric pallet truck according to this instruction manual.

The trucks described in this manual are self-propelled electric power pallet trucks. The trucks are designed to lift, lower and transport palletized loads.

A wrong usage can cause human injuries or can damage the equipment.

The operator/ the operating company has to ensure the correct usage and has to ensure, that this pallet truck is used only by staff, who is trained and authorized to use this truck.

The pallet truck has to be used on substantially firm, smooth, prepared, level and adequate surfaces. The truck is intended to be used for indoor applications with ambient temperatures between +5°C~+40°C and for various transportation applications without crossing permanent obstacles or potholes. The work on ramps is allowed if ramp is not exceeding the allowed angle. While operating, the load must be placed approximately on the longitudinal centre plane of the truck.

Lifting or transporting people is forbidden.

If used on tail lifts or loading ramps, please ensure that these are used correctly according to the operating instructions.

The capacity is marked on capacity sticker as well on the Identification plate. The operator has to consider the warnings and safety instructions.

Operating lighting must be minimum 50 Lux.

## Modification

No modifications or alterations to this pallet truck which may affect, for example, capacity, stability or safety requirements of the truck, shall be made without the prior written approval of the original truck manufacturer, its authorized representative, or a successor thereof. This includes changes affecting, for example braking, steering, visibility and the addition of removable attachments. When the manufacturer or its successor approve a modification or alteration, they shall also make and approve appropriate changes to capacity plate, decals, tags and operation and maintenance handbooks.

## 2. DESCRIPTION OF THE PALLET TRUCK

### a. Overview of the main parts

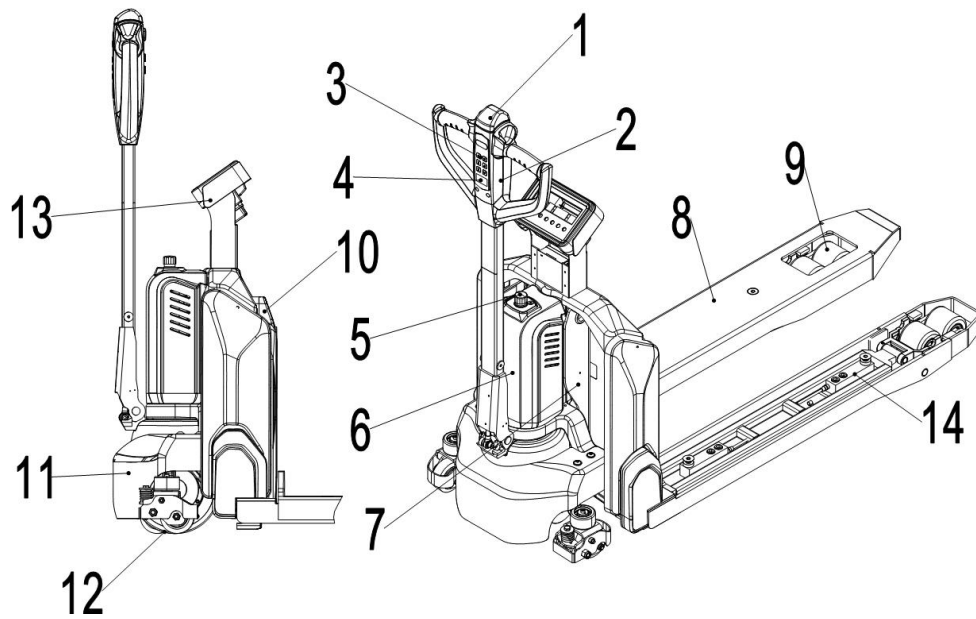

Fig. 1: Overview main parts

- |                                |                |
|--------------------------------|----------------|
| 1. Safety (belly) button       | 8. Fork        |
| 2. Tiller                      | 9. Load roller |
| 3. Pin-code panel              | 10. Battery    |
| 4. Battery discharge indicator | 11. Apron      |
| 5. Emergency button            | 12. Drive Unit |
| 6. Motor cover                 | 13. Display    |
| 7. Chassis                     | 14. Sensors    |

## b. Main technical data

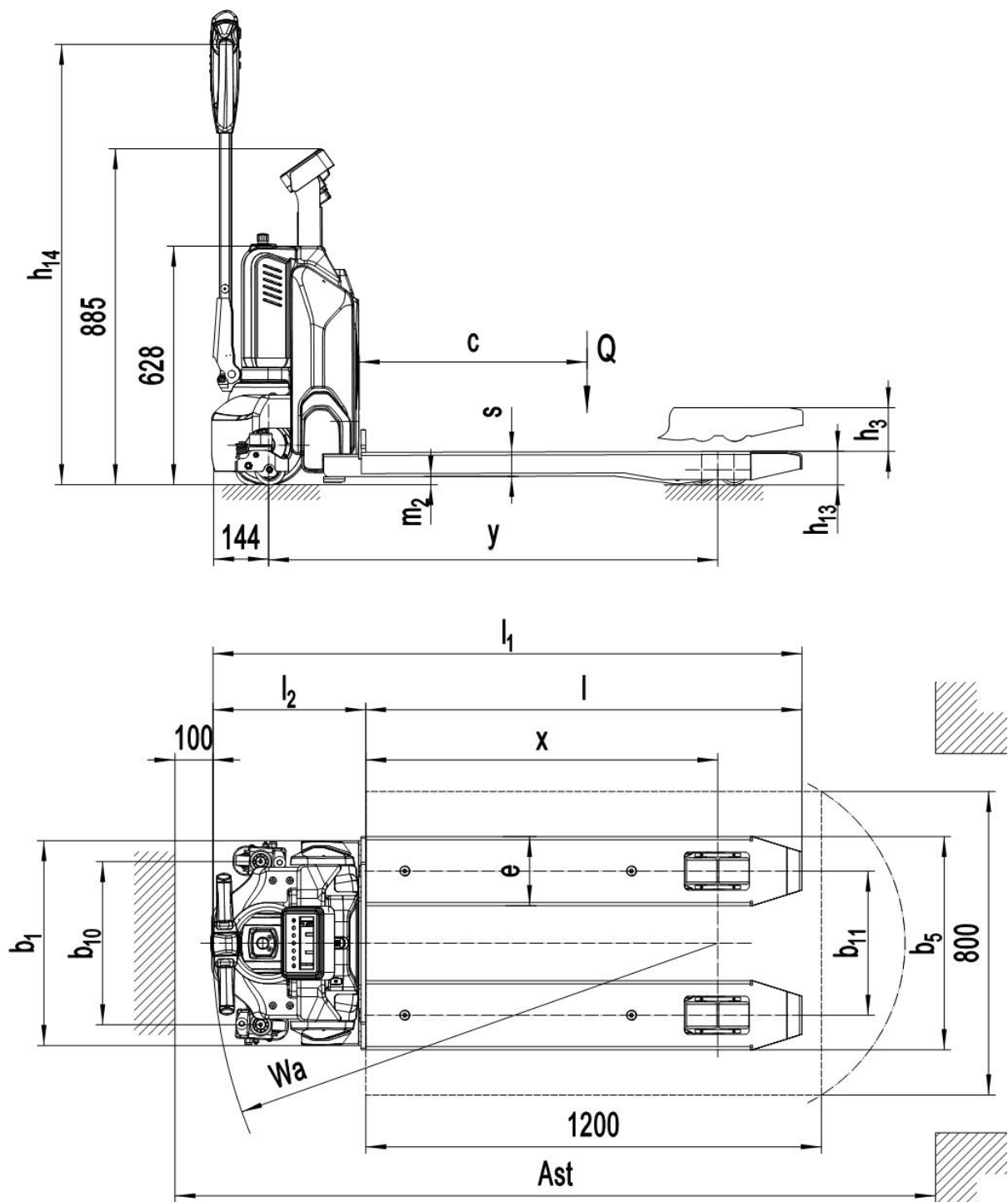

Fig. 2: Main technical data



Table 1: Main technical data for standard version

Type sheet for industrial truck acc. to VDI 2198						
Distinguishing mark	1.2	Manufacturer`s type designation		PTE15N SC		
	1.3	Drive		Battery		
	1.4	Operator type		Pedestrian		
	1.5	Load Capacity / rated load	Q (t)	1.5		
	1.6	Load centre distance	c (mm)	600		
	1.8	Load distance ,centre of drive axle to fork	x (mm)	928		
	1.9	Wheelbase	y (mm)	1183		
Weight	2.1	Service weight	kg	180	185	
	2.2	Axle loading, laden front/rear	kg	472/1208	476/1209	
	2.3	Axle loading, unladen front/rear	kg	121/59	121/64	
Tyres, chassis	3.1	Tires		Polyurethane (PU)		
	3.2	Tire size,front	∅ x w (mm)	∅ 210x70		
	3.3	Tire size,rear	∅ x w (mm)	∅ 80x93(∅ 80x70)		
	3.4	Additional wheels(dimensions)	∅ x w (mm)	-/∅ 80x30		
	3.5	Wheels,number front/rear(x=driven wheels)		1x/ 2(1x/ 4) or 1x +2/ 2(1x +2/ 4)		
	3.6	Tread, front	b <sub>10</sub> (mm)	-/430		
	3.7	Tread, rear	b <sub>11</sub> (mm)	380	525	
Dimensions	4.4	Lift	h <sub>3</sub> (mm)	115		
	4.9	Height of tiller in drive position min./ max.	h <sub>14</sub> (mm)	740 / 1162		
	4.15	Height, lowered	h <sub>13</sub> (mm)	88		
	4.19	Overall length	l <sub>1</sub> (mm)	1560		
	4.20	Length to face of forks	l <sub>2</sub> (mm)	410		
	4.21	Overall width	b <sub>1</sub> (mm)	540		
	4.22	Fork dimensions	s/e/l (mm)	64 / 182 / 1150		
	4.25	Distance between fork- arms	b <sub>5</sub> (mm)	562	707	
	4.32	Ground clearance, centre of wheelbase	m <sub>2</sub> (mm)	21		
	4.34	Aisle width for pallets800X1200 lengthways (200mm safe distance)	A <sub>st</sub> (mm)	2000		
	4.35	Turning radius	W <sub>a</sub> (mm)	1387		
Performance data	5.1	Travel speed, laden/ unladen	km/h	4.2 4.4		
	5.2	Lift speed, laden/ unladen	m/s	0.015 / 0.022		
	5.3	Lowering speed, laden/ unladen	m/s	0.05 / 0.04		
	5.8	Max. gradeability, laden/ unladen	%	6 / 16		
	5.10	Service brake		Electromagnetic		
Electric- engine	6.1	Drive motor rating S2 60min	kW	0.65		
	6.2	Lift motor rating at S3 10%	kW	0.50		
	6.3	Battery acc. to DIN 43531/ 35/ 36 A, B, C, no		No		
	6.4	Battery voltage, nominal capacity K5	V / Ah	24 / 20(24 / 30; 24 / 36)		
	6.5	Battery weight	kg	4.6		
	6.6	Energy consumption acc. to VDI cycle	kWh/h	0.19		
Addit	8.1	Type of drive control		DC speed Control		
	8.4	Sound level at driver`s ear acc. to EN 12053	dB(A)	<70		

Features weighing accuracy:  $\pm 1.5\text{kg}$  for loading 1500kg

### c. Description of the safety devices and warning labels (Europe and other, excepting USA)

- A Decal: No Passengers
- B Decal: Crane Hook
- C Label: Identification plate (ID-plate)
- D Decal: read and follow the instructions
- E Decal: oil filling port
- F Label: Capacity

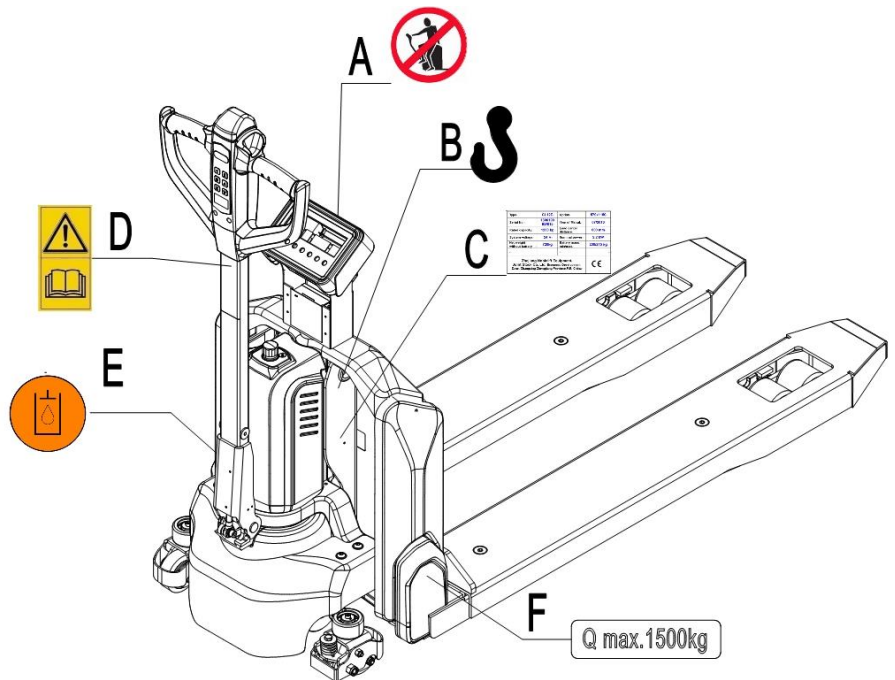

Fig. 3: Warning labels and decals

The truck is equipped with an emergency button (5) which stops functions of lifting, lowering, driving and engages the fail-safe electromagnetic brake when it is pressed. After checking the functions of the controller, turn this button clockwise and the truck can be

operated. Before operating, press the passwords on pin-code panel and press “√” button.

To prevent the unauthorized access, press emergency button (5) or press “X” button of pin-code panel. The truck is equipped with a safety (belly) button (1) which switches the driving function away from the operator, if the truck travels towards the operator and the tiller is activated in the tillers operating zone. Follow also the instructions given on the decals. Replace the decals if they are damaged or missing.

### d. Identification plate

Pallet Truck			
Type	xxxx	Rated capacity	xxxx kg
Rated voltage	xx V	Service weight	xxxx kg
Battery mass max.	xxx kg	Battery mass min.	xxx kg
Net weight (no battery)	xxx kg	Max. lifting height	xxxx mm
Serial Number	XXXXXXXXXX	Truck code	XXXXXXXXXX
Manufacturer XXXXXXXXXXXXXXXX			

Fig. 4: Identification plate (take practicality as standard)

### 3. WARNINGS, RESIDUAL RISK AND SAFETY INSTRUCTIONS

#### DO NOT



- Put feet or hands under or into the lifting mechanism.
- Allow other person than the operator to stand in front of or behind the truck when it is moving or lifting/lowering.
- Overload the truck.
- Put feet in front of the wheels, injury could result.
- Lift people. People could fall down and suffer severe injury.
- Push or pull loads
- Side or end load. Load must be distributed evenly on the forks.
- Use the truck with unstable, unbalanced not stable load.
- Use truck without manufacturer's instructions manual.
- Lifted loads could become unstable at wind forces. In the case of wind forces do not lift the load if there is any influence to the stability.

Watch difference in floor levels when driving, load could fall down or the truck could get uncontrollable. Keep watching the conditions of load. Stop operating the truck if load becomes unstable.

Brake the truck and activate the emergency button (5) by pushing when sliding load on or off the truck. If the truck has any malfunctions, follow chapter 10.

Practice maintenance work according to regular inspection. This truck is not designed to be water resistant. Use the truck under dry condition. Prolonged continuous operation might cause damage to the power pack. Stop operation if temperature of hydraulic oil is too high.



- When operating the electric pallet truck, the operator has to wear safety shoes.
- The truck is intended to be used for indoor applications with ambient temperatures between +5°C and + 40°C.
- The operating lighting must be minimum 50 Lux.
- To prevent unintended sudden movements when not operating the truck (i.e. from another person, etc.), turn off the truck.

### 4. COMMISSIONING, TRANSPORTING, DECOMMISSIONING

#### a. Commissioning

Table 2: Commissioning data

Type	PTE15N SC(562X1150)	PTE15N SC(707X1150)
Commissioning weight [kg]	180kg	185kg
Dimensions [mm]	1552x560x1250	1552x707x1250

After receiving our new pallet truck or for re-commissioning, you have to do following steps before (firstly) operating the truck:

- Check if all parts are included and not damaged.
- Check if all functions of the tiller work normally.
- Check if proper batteries and chargers are used (follow chapter 8).
- Complete the daily inspections as well as functions check.

## b. Hoisting/ transportation

For transporting, remove the load, lower the forks to the lowest position and fix the truck with dedicated hoisting equipment according to the following figures.

### Hoisting



USE DEDICATED CRANE AND HOISTING EQUIPMENT

DO NOT STAND UNDER THE SWAYING LOAD

DO NOT WALK INTO THE HAZARDOUS AREA DURING HOISTING OPERATION

### Transportation



ALWAYS FASTEN THE TRUCK SECURELY DURING TRANSPORTATION ON A LORRY OR TRUCK

Lower the forks and park the truck securely.

Fasten the truck according to Fig. 6 by fixing dedicated lashing belts to each side of the hook holes and fasten the other side at the transporting truck.

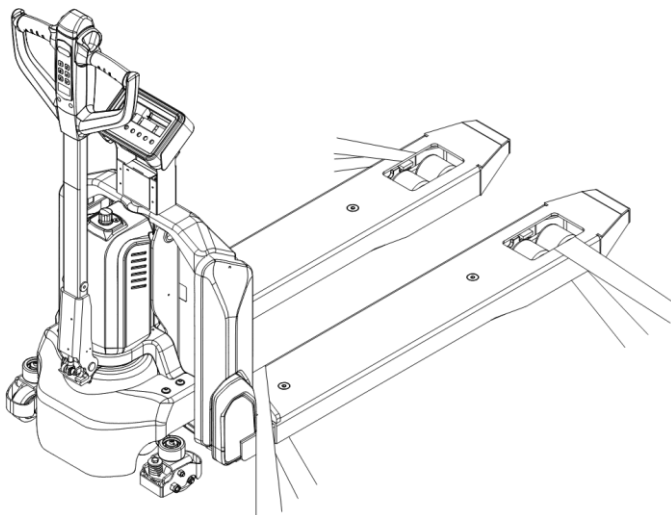

Fig. 5: Lifting with a crane

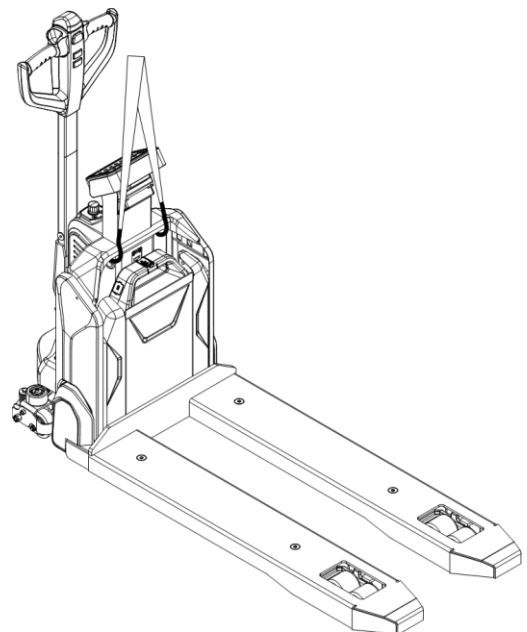

Fig. 6: Holes for hook

## c. Decommissioning

For storage, remove the load, lower the truck to the lowest position, grease all greasing points (regular inspection) mentioned in this manual to protect the truck against corrosion and dust. Remove the batteries and check safety equipment so that there will be no crush after storage.

For final decommissioning hand the truck to a designated recycling company. Oil, batteries and electric components must be recycled due to legal regulations.

## 5. DAILY INSPECTION

This chapter describes pre-checks before putting the truck into operation.

Daily inspection is effective to find the malfunctions or faults on this truck. Check the following points before operation.

Remove load from truck and lower the forks.



**DO NOT USE THE TRUCK IF ANY MALFUNCTION IS FOUND.**

- Check for scratches, deformation or cracks.
- Check if there is any oil leakage from the cylinder.
- Check the vertical creep of the truck.
- Check the smooth movement of the wheels.
- Check the function of the emergency brake by activating the emergency button.
- Check the braking function of tiller.
- Check the lifting and lowering functions by operating the buttons.
- Check if all bolts and nuts are tightened firmly.
- Visual check if there are any broken electric wires.
- If the truck equips with a backrest, check it for damages and correct assembling.

## 6. OPERATING INSTRUCTIONS



**BEFORE OPERATING THIS TRUCK, PLEASE FOLLOW THE WARNINGS AND SAFETY INSTRUCTIONS (CHECK CHAPTER 3).**

Make sure that the load is stably palletized and the daily inspection is carried out.

Type the passwords on pin-code panel (3) and press “√” button to start the truck.

Press the horn button (Fig.7,14) to activate the audible warning signal.

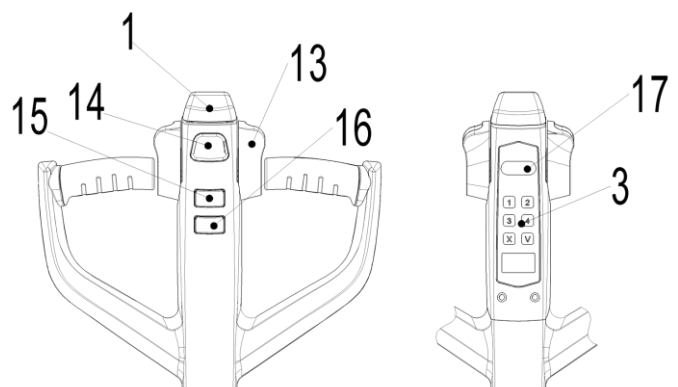

**Fig.7:** Tiller operating controls

### a. Parking



DO NOT PARK THE TRUCK ON INCLINED SURFACES

The truck equips with an electromagnetic fail-safe stopping and parking brake. Please fully lower the forks and press the emergency button (5).

### b. Lifting



DO NOT OVERLOAD THE TRUCK! MAXIMUM CAPACITY IS 1500KG WHEN THE LOAD CENTER IS 600MM.

Fully lower the forks when drive the truck until loading. Press the lifting button (Fig. 7, 15) until to the desired lifting height.

### c. Lowering

Press the lowering button (Fig. 7, 16) carefully. Lower the load until the forks are clear of the pallet, then drive the truck carefully out of the load zone.

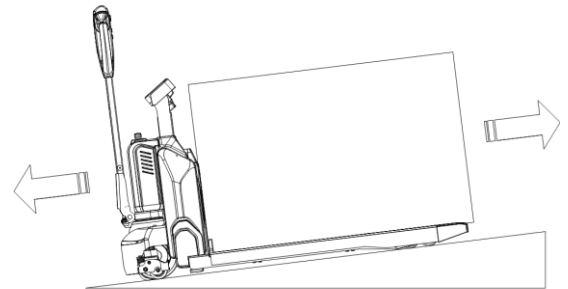

Fig. 8: Load uphill

### d. Travelling



TRAVEL ON INCLINES ONLY WITH THE LOAD FACING UPHILL (fig.8). DO NOT TRAVEL ON INCLINES MORE THAN SPECIFIED TECHNICAL DATA.

Start the truck by activation from Pin-code panel, move the tiller to the operating zone ('F', Fig.9).

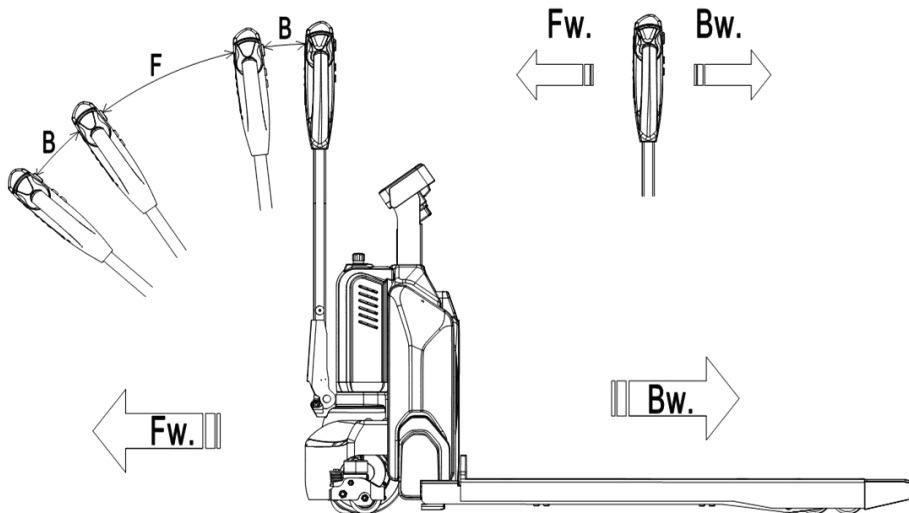

Fig. 9: Operating direction

Turn the accelerator to the desired direction forward 'Fw.' or backwards Bw.' (Fig. 9). Control the travelling speed by moving the accelerator (Fig.7,13) carefully until you reach the desired speed. If you move the accelerator back to the neutral position, the controller decelerates the truck until the truck stops. If the truck stops, the parking brake will be engaged.

Drive carefully the truck to the destination. Watch route conditions and adjust the speed by accelerator. Press turtle button (Fig.7,17) once to enter slow speed mode, move the accelerator (Fig.7,13) and the truck travels slowly. Press turtle button the second time to regular mode. Press turtle button (Fig.7,17) and hold for 2 seconds to realize driving with tiller in vertical position, move the accelerator and the truck can travel slowly, which is suitable for work in confined area.

### **e. Steering**



Steer the truck by moving the tiller to left or right side.

### **f. Braking**



PLEASE CHECK THE BRAKING DISTANCE WITH TRUCK BEFORE OPERATION  
THE BRAKING PERFORMANCE DEPENDS ON THE TRACK CONDITIONS AND  
THE LOAD CONDITIONS OF THE TRUCK

The braking function can be activated in several ways:

- By moving the accelerator (13) back to the initial '0' position or by releasing the accelerator, the regenerative braking is activated. The truck brakes until it stops.
- By moving the accelerator (13) from one driving direction directly to the opposite direction, the regenerative brake brakes the truck until it starts traveling into the opposite direction.
- The truck brakes, if the tiller is moved up or down to the braking zones ('B'). If the tiller is released, the tiller moves automatically up to the upper braking zone ('B'). The truck brakes until it stops.
- The safety (belly) button (1) prevents the operator from being crushed. If this button is activated, the truck decelerates and/ or starts traveling into the backwards direction ('Bw.') for a short distance and stops. Please consider, that this button also operates, if the truck is not traveling and the tiller is in the operating zone.

### **g. Malfunctions**

If there are any malfunctions or the truck is inoperative, please stop using the truck and activate the emergency button (5) by pressing it. If possible, park the truck on a safe area and press "X" button of pin-code panel. Inform immediately the manager and/ or call your service. If necessary, move the truck out of the operating area by using dedicated towing/ lifting equipment.

### **h. Emergency**

In emergencies or in the event of tipping over (or off dock), keep a safe distance away. If possible press the emergency button (5). All electrical functions will be blocked.

# 7. WEIGHING TERMINAL

## a. Accurate weighing

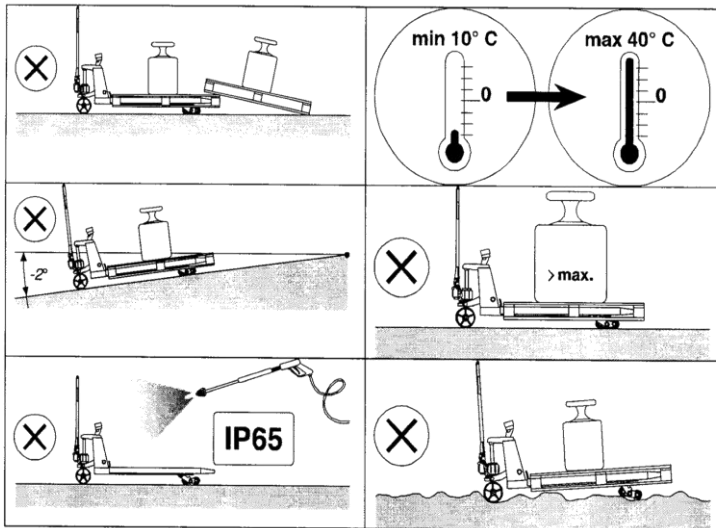
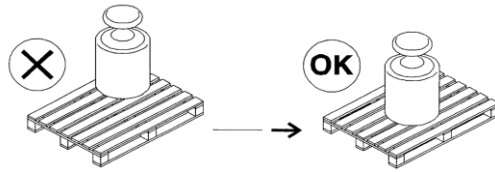

## b. 1 (Net) + 2 (Tare) = 3 (Gross)

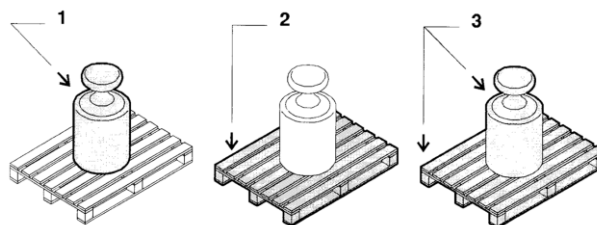

## c. Errors

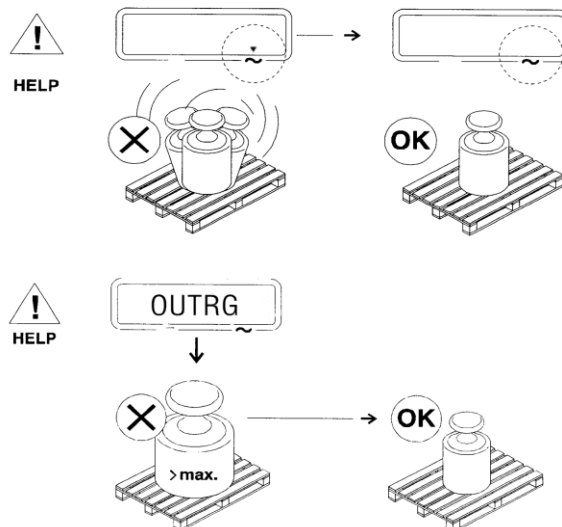



## d. Zero and tare functions

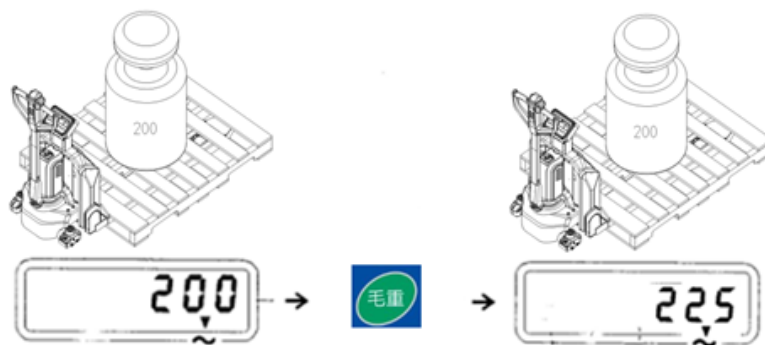
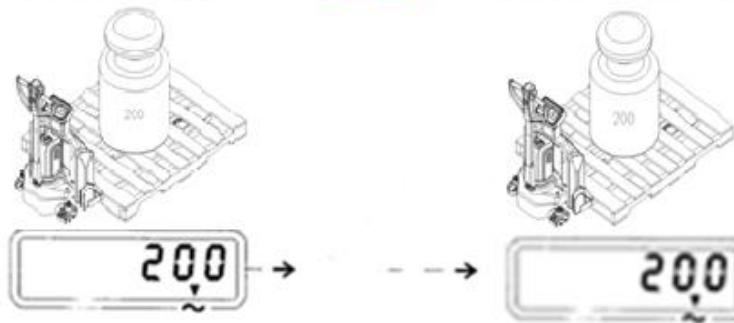
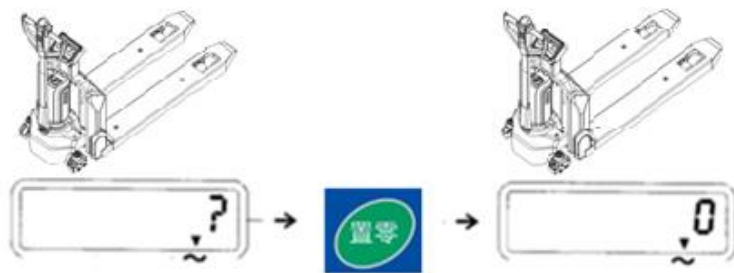

### e. Summation (total) function

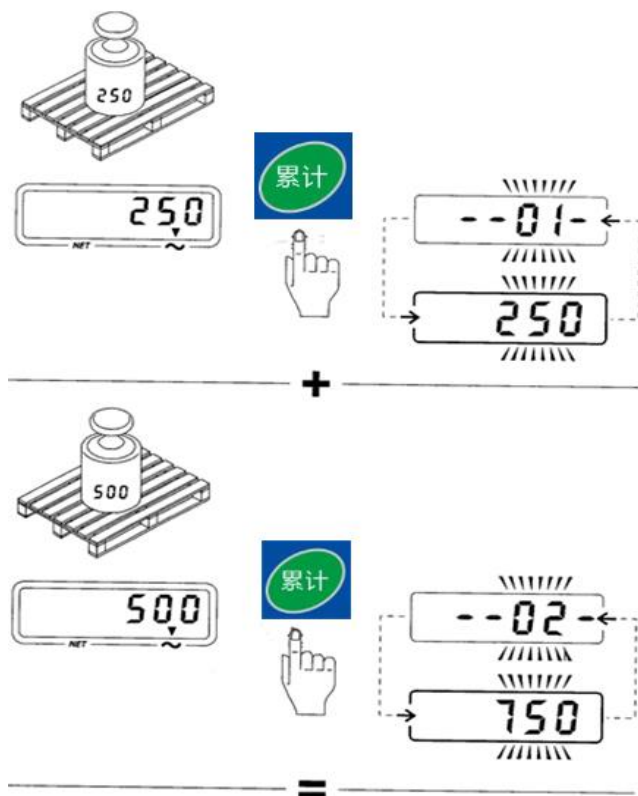

### f. Printer (Optional)

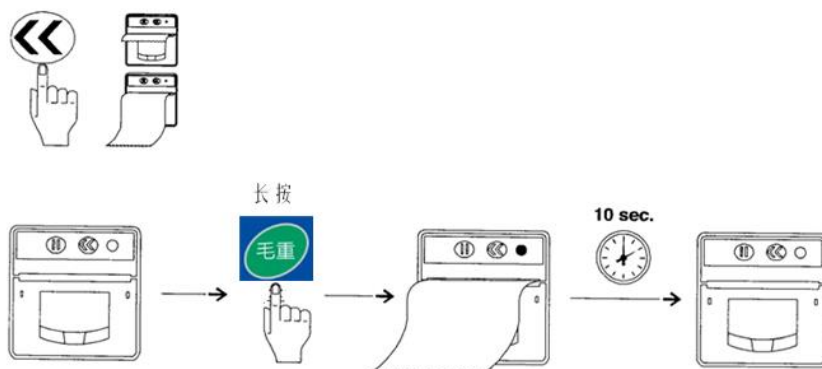

Printer	Thermal Printer	Print speed	Up to 65 mm/sec (max.)
Function	Front side paper feed, easy to install paper	Temperature range	-10~55°C
Paper	Thermal roll, maximum diameter is 50mm, width is 58mm	Dimensions	85x85x54mm
Resolution	8 dots/ mm, 384 dots/ line	Power supply	DC5V, DC5V-9V (optional)

## g. Printout (Optional)



## h. Paper replacement

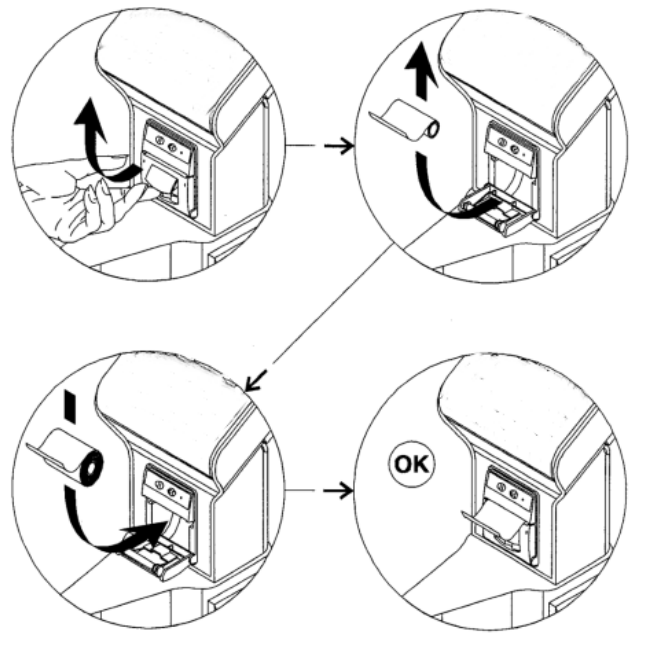

## 8. Indicator display

### a. Button and Display Check

#### Operations:

With the display off, long press and hold **Zero** button, then press **On/ Off** button, the device will enter hardware check state. Release **Zero** button when screen shows "0 OK". When the screen displays "0 KEY", press **Zero** button, the screen shows "0 OK";

Then "T KEY", press **Tare** button, the screen shows "T OK";

Then "U KEY", press **lb/kg** button, the screen shows "U OK";

Then "P KEY", press **Gross** button, the screen shows "P OK";

Then "A KEY", press **Total** button, the screen shows "A OK";

Then “H KEY”, press **Hold** button, the screen shows “H OK”—If all the operations are completed, then all buttons are OK.

When screen displays “P--BL”, press Tare button, the screen will display all contents and backlight on. Press Tare button again to empty the screen and backlight off. Press Tare button again, the screen shows “HCKOK”. If your operation and manual coincide, it means the screen and backlight OK.

## b. Default Unit Settings

When screen displays “SETUP”, press **Tare** (Confirm) button to enter into parameter setting mode. Check the default unit setting when the screen displays “UNIT”. Then press **Tare** (Confirm) button to confirm entering into this mode.

### Operations:

Press the **Tare** (Confirm) button to enter Default Unit Settings when in UNIT interface. Check the default unit at the right of the screen. Press the **Gross** (<—>) button to switch the unit. Press the **Tare** (Confirm) button again to confirm when the screen shows the desired unit.

After setting the default unit, next is to set the backlight. When the screen displays BLMOD, press **Tare** (Confirm) button to enter backlight mode setting, or press **lb/kg** (Cancel) to cancel and enter the next setting.

## c. Backlight Mode Settings

When the screen displays BLMOD, press **Tare** (Confirm) button to enter backlight mode setting, or press **lb/kg** (Cancel) button to cancel, then go to the next setting.

Backlight mode setting is set disabled by default, and can be enabled by long press **Zero** (Backlight) button when in weighing mode. When backlight is on, the screen will display the backlight cursor (the triangle above LIGHT).

### Operating Method:

When in BLMOD interface, press **Tare** (Confirm) button to enter backlight settings. Then press **Gross** (<—>) button continuously to switch the display content. It will loop the below 3 modes.

1) BL ON: means backlight mode on. When in weighing mode, long press **Zero** (Backlight) button to turn on backlight, and will last for 10 seconds.

2) BL OFF: means backlight mode off. When in weighing mode, long press **Zero** (Backlight) will be of no use.

3) BL AT: means auto backlight mode. When in weighing mode, the backlight will be automatically on once weight change has been detected. Backlight will last 10 seconds if the weighing goes stable.

Press **Tare** (Confirm) button to confirm the setting and go to the next setting.

## d. Calibration

Calibrate the device with Calibration function if the weighing result is not correct (Calibration unit is kg). Calibrate only one time during each operation.

When the screen displays CALBN, it's the calibration mode. Make sure there's no goods on the truck's forks. Press **lb/kg** (Cancel) button to cancel and enter the weighing mode after setting the parameters. Or press **Tare** (Confirm) to enter calibration settings. (Note: It's suggested to press **lb/kg** (Cancel) button to cancel the calibration and enter Weighing mode if the user only wants to set the default unit or BLMOD when the weighing result is correct.)

### Operating Method:

Press **Tare** (Confirm) button to enter Calibration mode when in CALBN interface. Put the weight on the truck's forks when the "---" cursor stops flickering and displays "00000" on the screen. Continuously press **Zero** (Input) button to loop the numbers from 0 to 9 for the digit with cursor below it, and press **Gross** (<—>) button to change the cursor position. Input the value of the weight by pressing **Gross** (<—>) button and **Zero** (Input) button, and then press **Tare** (Confirm) button to confirm. Calibration completed when the screen displays CALOK.

### e. Battery Replacement

Storage battery: 6V/4.5A (68.5mm\*46.5mm\*100mm).

First remove the screws of the battery cover, then replace the used batteries with the new ones. At last put back the battery cover and fix it with screws.

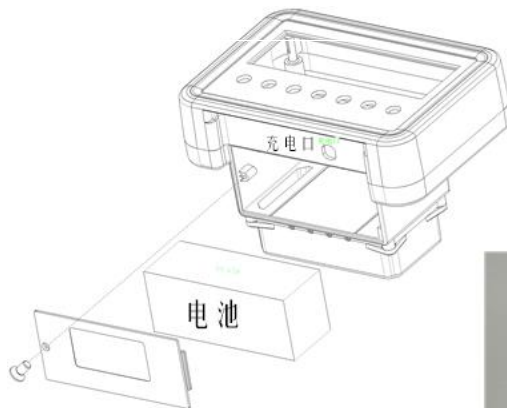

## f. Indicator operation panel

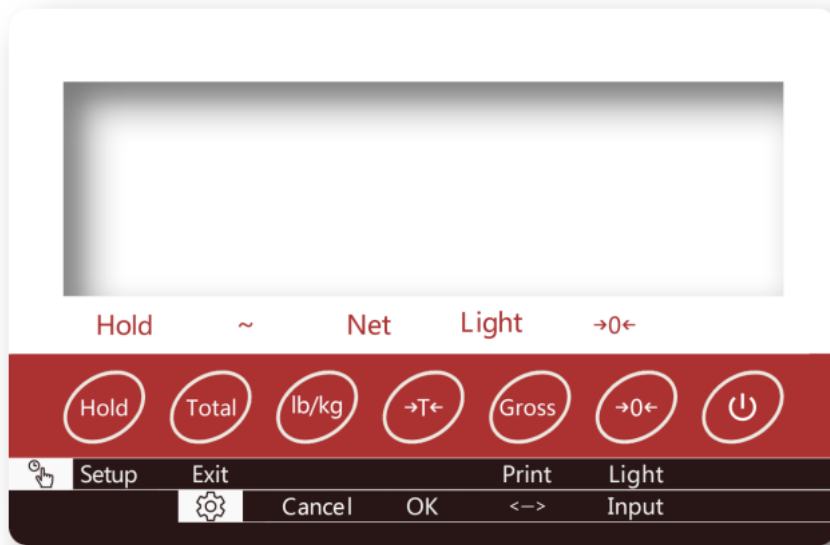

Note: this weighing display has 5 dynamic cursors: Hold (lock cursor), ~ (dynamic cursor), Net (net weight cursor), Light (backlight cursor), →0← (zero cursor) and 7 buttons: "Hold", "Total", "lb /kg", "Tare", "Gross", "Zero", "On/ Off".

Short press or long press one button or press two buttons at the same time to achieve different functions.

## g. Sensors Installation

1) Before the sensors installation, please make sure to power off the device head. The sensors will be in loop detection state if the device head is powered on. Operation with electricity will cause wrong data.

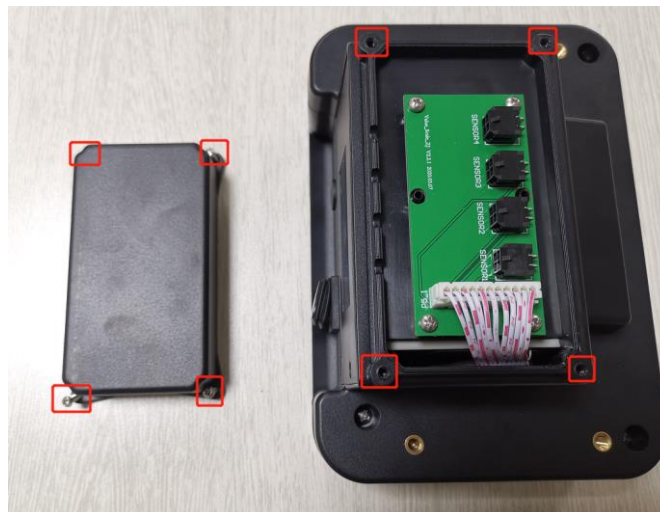

2) Remove four M3 Phillips screws at four corners of the sensor box. Open the box and join the 4 sensors to the 4 connectors.



- 3) Find the black waterproof rubber ring and white cable tie at the end of each sensor connector harness.
- 4) Put white cable tie into the box and the rubber ring into the slot for outgoing cables.
- 5) Put back the cover and fix it with screws.

## h. Button Functions

### 1) Single Button Function



**Short Press** - lock / unlock the weight value displayed on the current screen ; in weighing mode, press the "Hold" button on the operation panel, the current weight displayed will be locked, and the lock cursor will show at this time. If the weight is in the locked state, press the "Hold" button again to unlock it. Then it will return to the weighing state, and the lock cursor disappears. If it is in the weight lock state, functions like tare, total, zero will be rejected.

**Long Press** – enter into parameter setting mode.



**Short Press** - weight accumulation button. (1) Under weighing mode, the final weight will be the value when the dynamic cursor disappears. Press the "Total" button, the weight will be accumulated, and the accumulation time will be +1 , the screen will alternately display the accumulation time and total weight; (2) When the goods are unloaded, the device value returns to zero, place the next goods to accumulate; ( 3 ) When there is no goods on the trunk's forks, press the "Total" button to display the total accumulation times and total weight.

**Long Press** - the screen displays “Σ OFF” and exit the accumulation mode.



**Short Press** – switch the display unit of current weight.



**Short Press** - Under the Gross Weight state, take the current weight as the tare value, and the device changes to the Tare mode.



**Short Press** – Under the Tare mode, restore the tare value and the device changes to Gross Weight mode.

**Long Press** - if there is a printing module, the current weighing result can be printed out. Note: Do not remove the goods when printing.



**Short Press** - reset the display value within allowed reset range (only allowed to reset when the displayed weight is less than 10kg).

**Long Press** - control the backlight according to the mode of the backlight setting. if the device is in "BL ON" mode, and the backlight cursor is displayed, long press to the button to turn on the backlight.



**Short Press** – power on / power off.

## 2) Combined Button Function

Press “lb/kg” and “Gross” button at the same time to restore factory settings (handle with care).

## 9. Pin-code panel

### a. Introduction

Pin-code panel is an electronic system which is similar with an electronic alarm system. Truck can not be operated before correct passwords were typed in, the main function is to prevent unauthorized operation. The product offers operation convenience and also helps the anti-theft and security of the truck.

### b. Main parameters

Work voltage: 12V-60V

Ambient temperature: -40°C to +90°C

IP level: IP65



## c. Main functions

Currently the truck can be operated after correct password was typed in. The passwords consist of 4 numbers ranging from 0 to 9.

There are two sets of passwords of the pin-code panel, one is the default user password "1234", that you can start the truck immediately. The other one is the administrator password "3232", that you can reset the user password according to the following steps:

- Type "3232", press "√" and release it.
- Type previous user password, press "√".
- Type new password and press "√", previous password will be changed.

In case you need to reset the password, please follow the procedures below:

- Type "123", press "√" and release it.
- Type "123" again, press "√" and release it. Password will be "1234".

## 10. BATTERY CHARGING AND REPLACEMENT



- Only qualified personnel are allowed to service or charge the batteries. The instructions of this handbook and from the battery- manufacturer must be observed.
- The batteries are lithium batteries.
- Recycling of batteries undergoes national regulations. Please follow these regulations.
- By handling batteries, open fire is prohibited!
- In the area of battery charging neither burning materials nor burning liquids are allowed. Smoking is prohibited and the area must be ventilated.
- Park the truck securely before starting charging or installing/changing the batteries
- Before finishing the maintenance work, make sure, that all cables are connected correctly and that there are no disturbing towards other components of the truck.

Lithium battery of the truck:

24V20Ah lithium battery, 4.5kg; 24V30Ah lithium battery, 6kg; 24V36Ah lithium battery, 7kg.



IT IS ONLY ALLOWED TO USE LITHIUM BATTERIES.

PLEASE CONSIDER THE MAXIMUM OPERATING TEMPERATURE OF THE BATTERIES.

### a. Replacement

Park the truck securely and press emergency button (5) to turn off the truck. Hold the battery grip and pull out the battery vertically.

The installation procedures are in the reverse order.

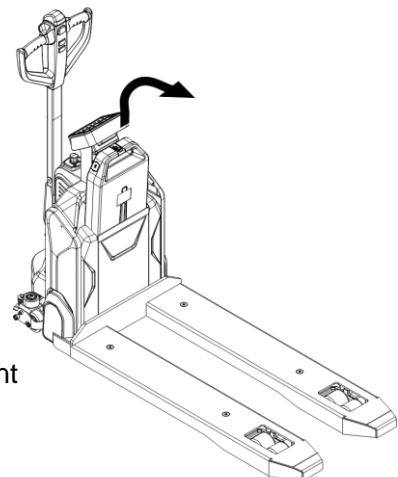

Fig. 10: Battery replacement

## b. Battery indicator

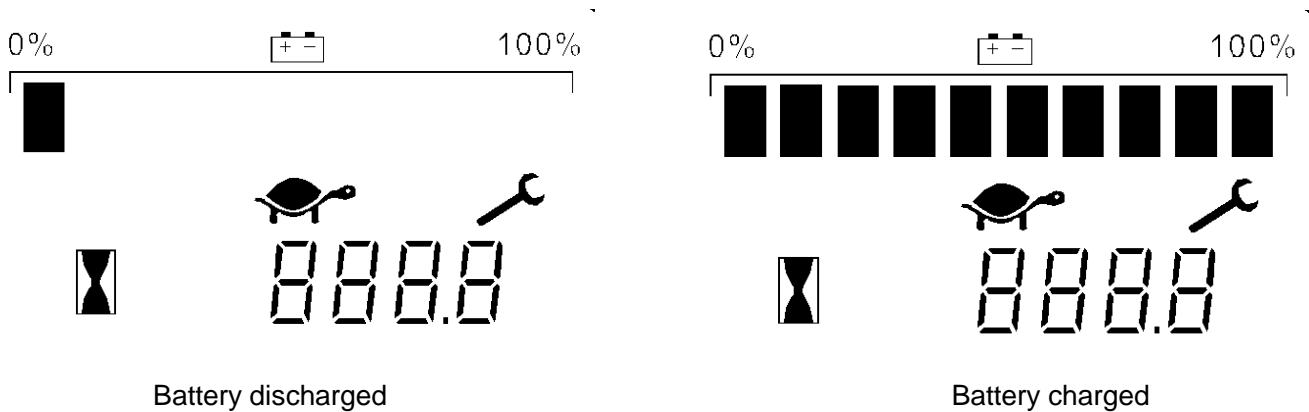

Fig. 11: Battery discharge indicator

### Hour meter

An alpha-numeric liquid crystal display is fitted in the centre of the unit that shows the hours worked.

### Fault Code

The display can indicate a code corresponding to the type of fault, and the wrench mark is flashing at the same time.

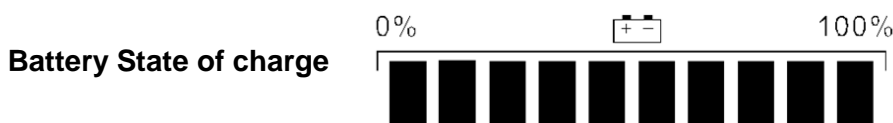

The battery's state of charge indication is integrated in the LCD display; it is shown by ten notches. Each notch represent the 10% of the battery charge. As the battery becomes discharged, the notches turn off progressively, one after the other, in proportion to the value of the residual battery charge.

**Turtle Symbol:** 

This symbol is normally off, when it appears (flashes) it shows activation of the “soft” mode of the truck, in which maximum speed and acceleration are reduced.

**Monkey Wrench Symbol:** 

This symbol is normally off, when it appears (flashes) it shows the request of programmed maintenance or the alarm state. In this case the relative code will be displayed.

**Hourglass Symbol:** 

This symbol is normally off, when it appears (flashes) it shows the hour meter is working.

## c. Charging

- Ensure that you are using an appropriate charger for charging the battery.
- Please fully understand the instructions manual for the charger before using it.
- Always follow these instructions.
- The room for charging must be ventilated.
- The full-charge status can be only checked from the discharge indicator. To control the status, the charging must be interrupted and the truck must be started.

Park the truck at a dedicated secured area with a dedicated power supply.

Lower the forks and remove the loads; Switch the truck off, connect the charger connector (18) to the power socket, connect the charger connector (19) to the charging port (20) on the battery. The charger starts charging the battery, after the charger finished charging, disconnect the charger connector from the battery and the power supply, then place the charger in the designated pocket.

Or remove the battery from the truck and place the battery next to designated power supply for charging. If you have the second spare battery, replace the original battery and charge the original battery.

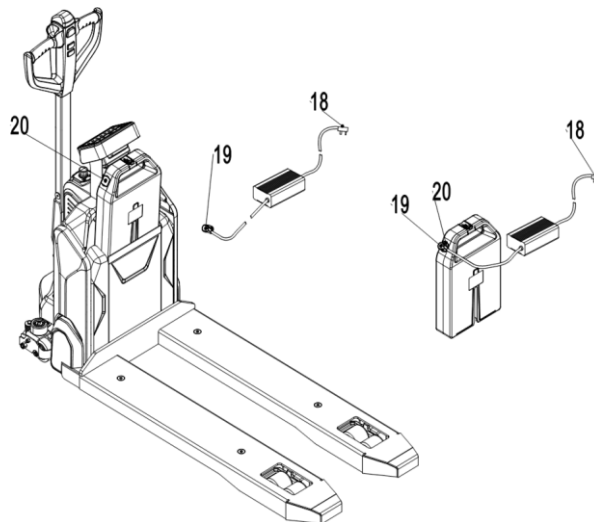

**Fig.12:** Battery charging

**Table 3:** Charger LED

LED- signal	Function
Red	Charging
Green	Fully charged

**Table 4:** Charger

Model	Specification	Input	Output
DZL2420SS02	24V5A (Chinese sticker)	180Vac -240Vac~2.0A MAX	29.4V 5.0A
DZL2420SS02	24V5A (English sticker)	100Vac -240Vac~2.0A MAX	29.4V 5.0A
DZL300SS02	24V8A (Chinese sticker)	180Vac -240Vac~3.0A MAX	29.4V 8.0A
DZL300SS02	24V8A (English sticker)	180Vac -240Vac~3.0A MAX	29.4V 8.0A
SSLC300V29	24V8A (EU)	180Vac -240Vac~3.0A MAX	29.4V 8.0A
SSLC300V29	24V8A (US)	108Vac -132Vac~5.0A MAX	29.4V 8.0A
QQE288-10CH109	24V12A	100Vac -240Vac~6.0A MAX	29.4V 12.0A

## 11. REGULAR MAINTENANCE

- Only qualified and trained personnel are allowed to do maintenance on this truck.
- Before maintenance, remove the loads from the forks and lower the forks to the lowest position.
- If you need to lift the truck, follow chapter 4 by using designated lashing or jacking equipment. Before working, put safety devices (e.g. designated lift jacks, wedges or wooden blocks) under the truck to protect against accidental lowering, movement or slipping.
- Please pay attention to the maintenance to the tiller arm. The gas spring is pre-assembled by compression, carelessness can cause injury.
- Use original spare parts which are approved and supplied from your dealer.
- Please consider that hydraulic oil leakage can cause failures and accidents.
- It is allowed to adjust the pressure valve by trained service technicians only.

If you need to change the wheels, please follow the instructions above. The castors must be round and they should have no abnormal abrasion.

Check the items emphasized in maintenance checklist.

### a. Maintenance checklist

Table 5: Maintenance checklist

		Interval (Month)			
		1	3	6	12
<b>Hydraulic</b>					
1	Check the hydraulic cylinder(s), piston for damage noise and leakage		•		
2	Check the hydraulic joints for damage and leakage		•		
3	Inspect the hydraulic oil level, refill if necessary		•		
4	Refill the hydraulic oil ( 12 month or 1500 working hours )				•
5	Check and adjust function of the pressure valve (1500kg+0/+10%)				•
<b>Mechanical system</b>					
6	Inspect the forks for deformation and cracks		•		
7	Check the chassis for deformation and cracks		•		
8	Check if all screws are fixed		•		
9	Check the push rods for deformation and damages		•		
10	Check the gearbox for noise and leakage		•		
11	Inspect the wheels for deformation and damages		•		
12	Inspect and lubricate the steering bearing				•
13	Inspect and lubricate the pivot points		•		
14	Lubricate the grease nipples	•			
<b>Electrical system</b>					
15	Inspect the electric wiring for damage		•		
16	Check the electric connections and terminals		•		

17	Test the Emergency switch function		•		
18	Check the electric drive motor for noise and damages		•		
19	Test the display		•		
20	Check, if correct fuses are used		•		
21	Test the warning signal		•		
22	Check the contactor(s)		•		
23	Check the frame leakage (insulation test)		•		
24	Check function and mechanical wear of the accelerator		•		
25	Check the electrical system of the drive motor		•		
Braking system					
26	Check brake performance, if necessary replace the brake disc or adjust the air gap		•		
Battery					
27	Check the battery voltage		•		
28	Clean and grease the terminals and check for corrosion and damage		•		
29	Check the battery housing for damages		•		
Charger					
30	Check the main power cable for damages			•	
31	Check the start-up protection during charging			•	
Function					
32	Check the horn function		•		
33	Check the air gap of the electromagnetic brake		•		
34	Test the emergency braking		•		
35	Test the reverse and regenerative braking		•		
36	Test the safety (belly) button function		•		
37	Check the steering function		•		
38	Check the lifting and lowering function		•		
39	Check the tiller arm switch function		•		
General					
40	Check if all decals are legible and complete		•		
41	Inspect the castors and adjust the height, replace castors if they are worn out.			•	
42	Carry out a test run		•		

## b. Lubricating points

Lubricate the marked points according to the maintenance checklist. The required grease specification is: DIN 51825, standard grease.

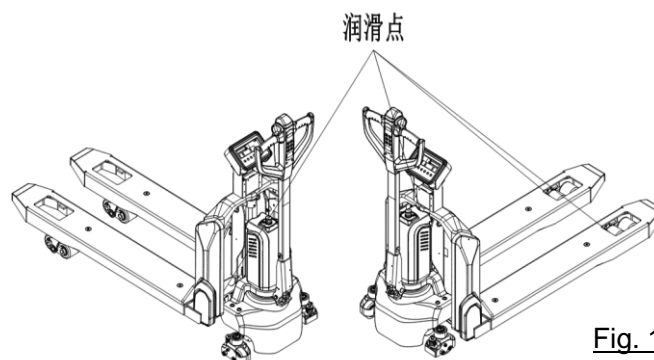

Fig. 13: Lubricating points

### c. Check and refill hydraulic oil

It is recommended to use hydraulic oil in connection with average temperature:

Environment temperature	-5°C~25°C	>25°C
Type	HVLP 32, DIN 51524	HLP 46, DIN 51524
Viscosity	28.8-35.2	41.4 - 47
Amount	0.4 L	

Waste material like oil, used batteries or other must be disposed and recycled according to the national regulations and if necessary, brought to a recycling company.

The oil level height shall be higher than the position of minimum mark.

If necessary add oil till oil level reaches the filling mark.

### d. Check electrical fuses

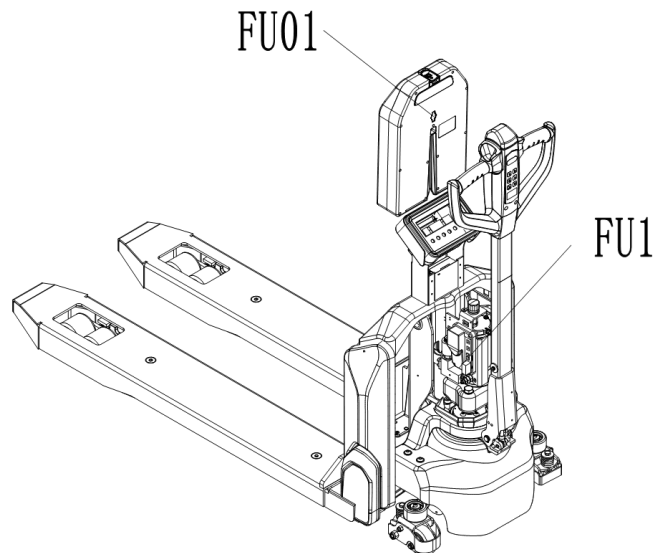

Fig. 14: Location of fuses

Table 6: Size of the fuses

	Rate
FU 1	10A
FU 01	70A

## 12. TROUBLE SHOOTING



- If the truck has malfunctions follow the instructions, mentioned in chapter 6.

Table 7: Trouble shooting

Fault	Possible cause	Solution
Load can not be lifted	Load weight is too heavy	Lift loads lighter than the max. capacity marked on the ID-plate
	Battery is discharged	Charge the battery

	Lifting fuse fault	Check and eventually replace the lifting fuse
	Hydraulic oil level is too low	Check and eventually refill hydraulic oil
	Oil leakage	Maintain the sealing of the cylinder
Oil leakage from air breathing	Oiliness is too high	Reduce oiliness
Truck can not be operated	Battery is charging	Fully charge the battery and then remove the main power plug from the power supply socket
	Battery disconnected	Connect the battery correctly
	Fuse fault	Check and eventually replace the fuses
	Low battery	Charge the battery
	Emergency switch is activated	Turn the emergency clockwise
	Tiller is not in the operating position	Move the tiller firstly to the braking zone

If the truck has malfunctions and can not be operated out of the working zone, jack the truck up and put the load handling equipment under the truck and ensure the safety of the truck. Then move the truck out of the aisle.

# 13. WIRING/ CIRCUIT DIAGRAM

## a. Electrical circuit diagram

Without speed reduction on curves

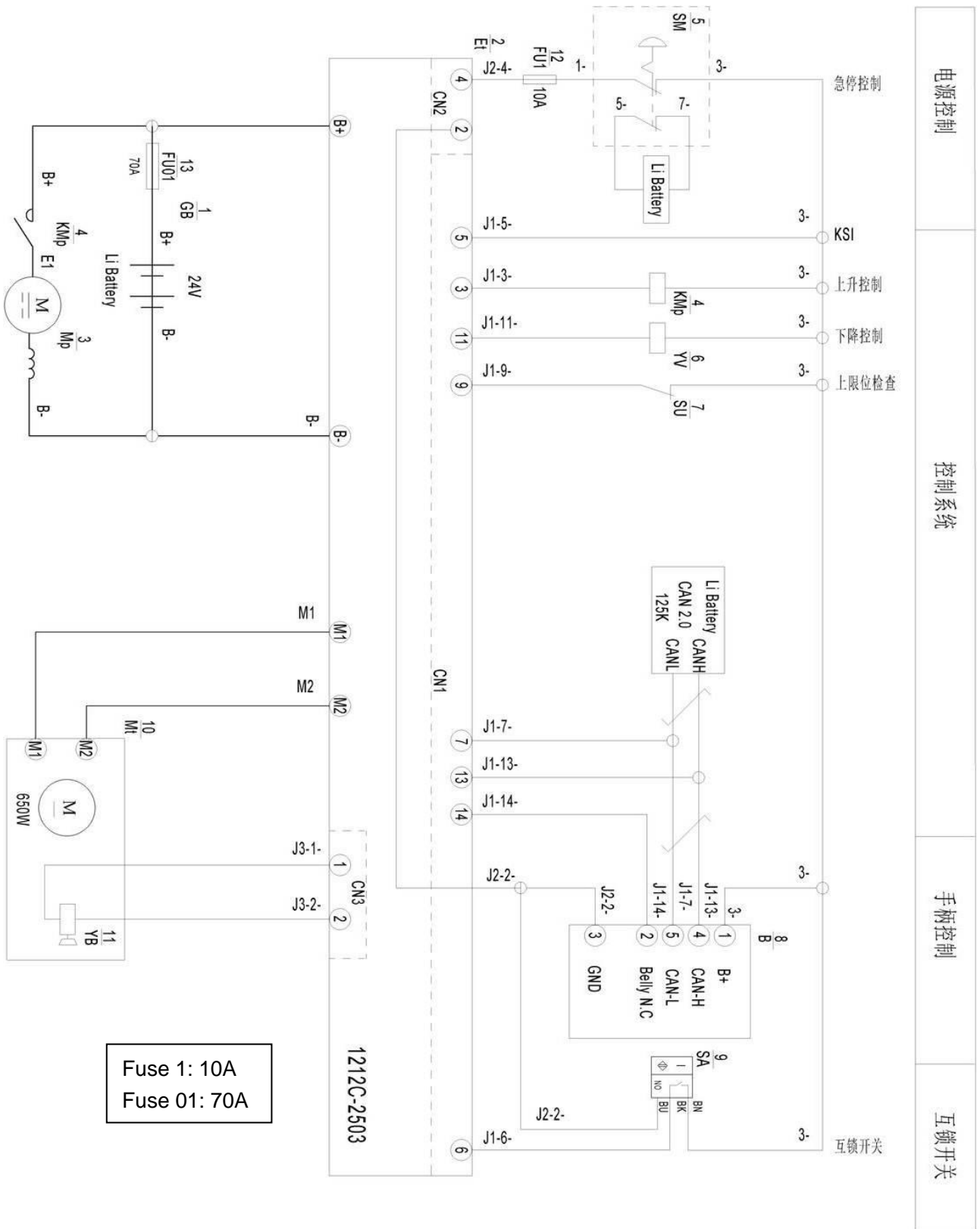

Fig.15: Electric circuit diagram (without speed reduction on curves)



Table 8: Description of electrical components

No.	Code	Item	No.	Code	Item
1	GB	Battery	8	B	CANTiller
2	Et	Controller	9	SA	Proximity Switch
3	Mp	Pump Motor	10	Mt	Traction Motor
4	KMp	Pump Contactor	11	YB	Electromagnetic Brake
5	SM	Emergency button	12	FU1	10A Fuse
6	YV	Electromagnetic Valve	13	FU01	70A Fuse
7	SU	Microswitch			

With speed reduction on curves

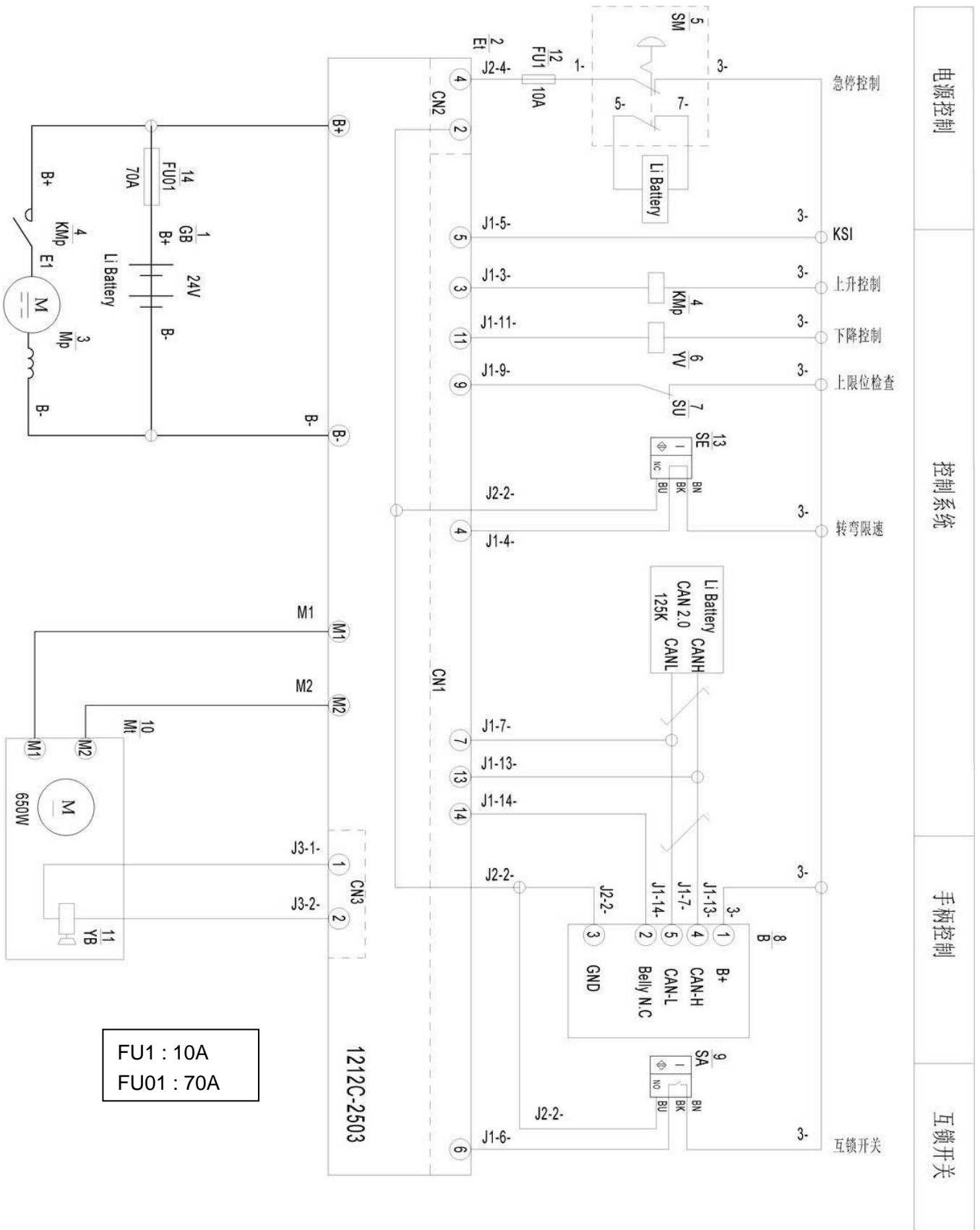

Fig.16: Electric circuit diagram (with speed reduction on curves)

Table 9: Description of electrical components

No.	Code	Item	No.	Code	Item
1	GB	Battery	8	B	CAN Tiller
2	Et	Controller	9	SA	Proximity Switch
3	Mp	Pump Motor	10	Mt	Traction Motor
4	KMp	Pump Contactor	11	YB	Electromagnetic Brake
5	SM	Emergency Button	12	FU1	10A Fuse
6	YV	Electromagnetic Valve	13	SE	Proximity Switch
7	SU	Microswitch	14	FU01	70A Fuse

## b. Hydraulic circuit diagram

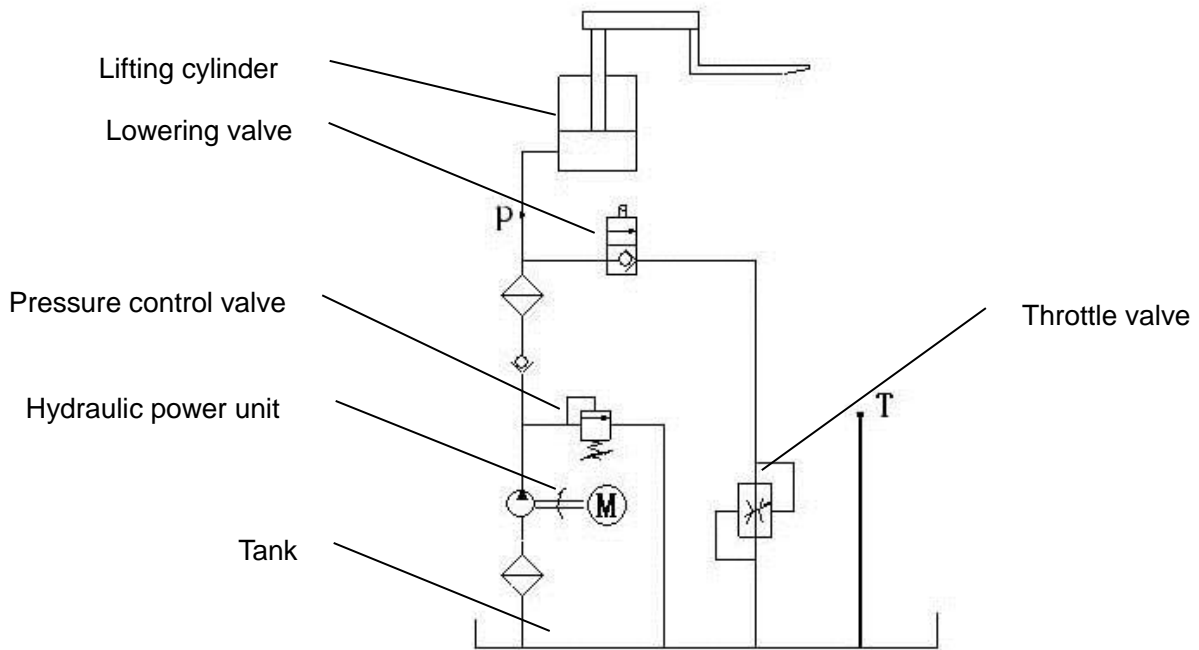

Fig. 17: Hydraulic circuit diagram